



**WS**  
**C+G**

## 全自動高速圓鋸機

HIGH SPEED CIRCULAR SAWING MACHINE

Scan Now



Official website

強效高速精準鋸切  
The Cutting Of High Speed And Accuracy

高端智慧人機觸控操作介面  
High-end Smart HMI Control Panel

成就力與美的動感  
Combination Of Force And Beauty

走在科技潮流尖端  
On The Cutting Edge Of Technology

# INTRODUCTION

## C SERIES (旗艦款 FLAGSHIP STYLE)

### 配備 Equipment

- 主馬達採用15 HP輸出驅動 (WS-75C)  
Motor Drives AC Drive 15HP (WS-75C)
- 自動偵測材料外徑系統  
Vise Detecting Material Size Automatically System
- 自動給油潤滑裝置  
Automatic Oiler Device
- 外罩拉門線性滑軌裝置  
Door Rail with Linear Guide

Model 型號	Page 頁次
Machine structure 機臺配備	03
Feature 特點說明	05 / 12
WS - 150 C	07
WS - 100 C	08
WS - 75 C	09

## G SERIES (標準款 STANDARD STYLE)

### 配備 Equipment

- 主馬達採用10 HP輸出驅動 (WS-75G)  
Motor Drives AC Drive 10HP (WS-75G)

WS - 75 G	10
WS - 100 G	11

## 驅動未來

*Driving The Future*

## 創新領航

*Navigation Innovations*



- 高剛性 High Rigidity
- 高轉速 High Speed
- 高精度 High Accuracy
- 高負載 Heavy Duty
- 高效能 High Efficacy
- 高智能 High Intelligence

# MACHINE STRUCTURE 機臺配備

刮板式自動除屑機

Scraper Type Automatic Chip Conveyor

特殊設計無間隙齒輪箱

Special Designed Backlashes Gear Head

智能人機控制介面

Smart HMI Control Panel

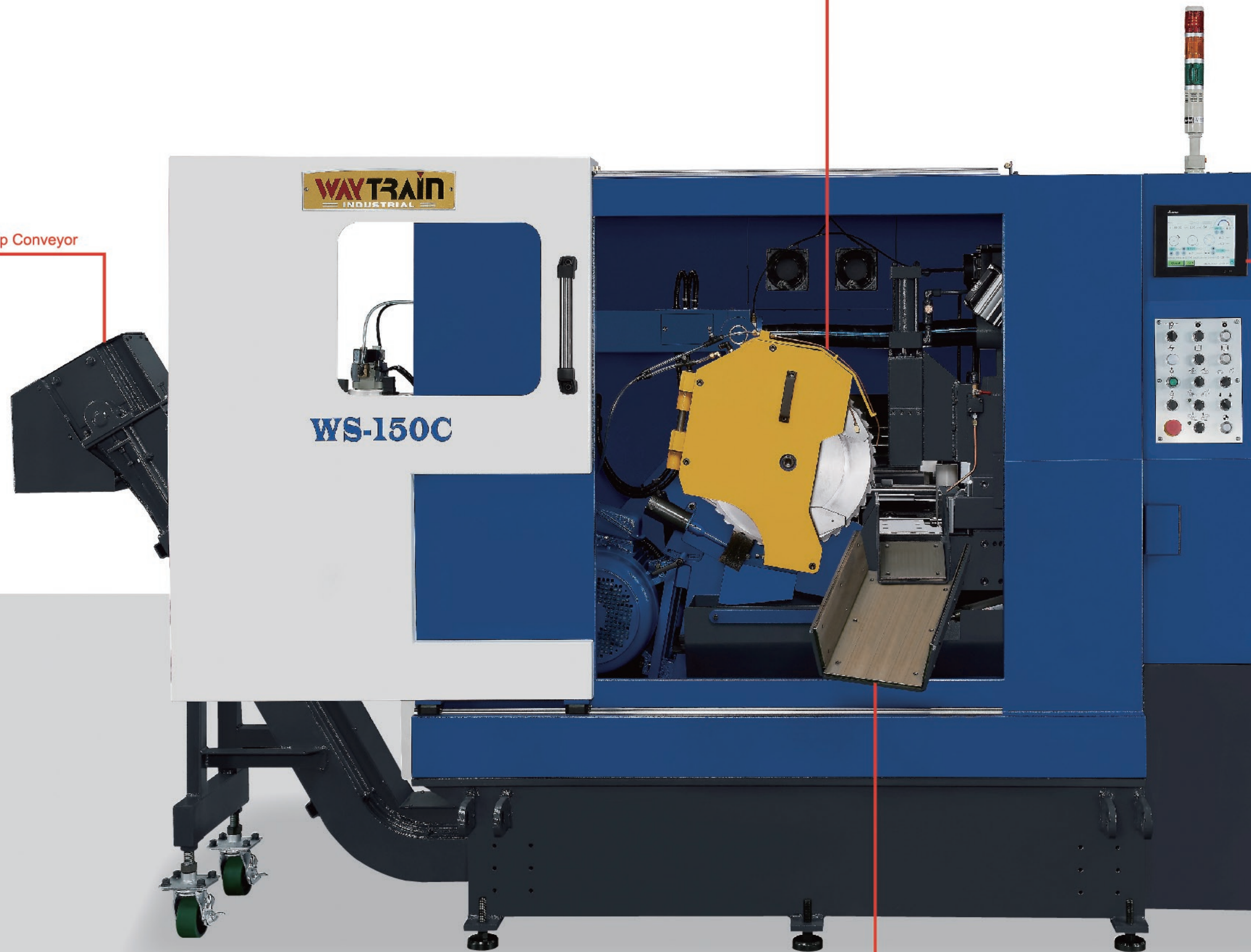

WS-150C

自動分料裝置

The Material Separation System

## 01 / 特殊設計無間隙齒輪箱

Special Designed Backlashes Gear Head

特殊精密設計強效無間隙齒輪箱可滿載鋸切不鏽鋼。  
The backlashes gear reducer for high efficiency cutting stainless.

## 02 / 動力除屑鋼刷

Powerful Chip Brush

油壓動力鋼刷裝置有效清除鐵屑增加切割效能。  
Hydraulic powerful chip brush for longer cutting result.

## 03 / 油霧冷卻系統

Mist oil spray system

油霧冷卻潤滑鋸片延長鋸片壽命。  
Mist oil spray to lubricate blade for cutting lifespan.

## 04 / 自動偵測材料外徑系統

Vise Detecting Material Size Automatically

自動偵測距切材料尺寸，防止鋸切干涉。  
The automatic detection of diameter could be prevented from the interference between the vise and the material during the cutting.

## 05 / 伺服送料油壓浮動床座

Servo Feeding with Hydraulic Floating Saddle

伺服定寸送料系統，結合浮動床座實現無干涉精準送料。  
The AC servo motor bar feeding system by ball screw and floating saddle for accurate feeding movement and cutting position.

## 06 / 材料固定油壓缸

Vertical Press

下壓缸固定材料，使夾料迅速精確材料不易鬆脫後退。  
The vertical cylinder press keep workpiece more firm and not easy of loose and backward during clamping.

## 07 / 自動分料裝置

The Material Separation System

端面、殘料與正常工件自動區分置放。  
The system can separate from trim cutting, residual material and normal material.

## 08 / 刮板式自動除屑機

Scraper Type Automatic Chip Conveyor

獨立自動排屑設計，可增加排屑順暢。  
The special designed for chip removal easily.

## 09 / 智能人機控制介面

Smart HMI Control Panel

8" 簡易控制面板，方便設定操作。  
The symbol-based 8" control panel is easy to understand and operate.  
自動顯示異常訊息與停機，智能偵測管理裝置。  
The notifications of malfunction diagnosing on touch screen and automatically stop the machine, the devices is managed by intelligent system.

## 10 / 外罩拉門線性滑軌裝置

Door Rail with Linear Guide

採用線性滑軌設計，使外罩拉門達到省力化與輕巧化運行。  
The linear guide allows door to push out and slide back upon opening smoothly.

## 11 / 自動進(儲)料架

Feeding Loader

多支料儲存 & 自動感測補料系統，效節省人力與時間。  
Materials stock and automatic material detection system to economize manpower and reduce working time.  
獨特油壓系統設計推動阻力小，撥料運轉無噪音。  
The special designed with hydraulic, low resistance for no noise in loading.  
活動式擋料板，方便機器操作維修。  
With the moveable baffle, it is convenient for maintenance.



### 規格表 SPECIFICATIONS

型號 MODEL		WS-150C
鋸切能力 Cutting Capacity	●	50 - 150 mm
	■	50x50 - 102x102 mm
鋸片馬達 Blade Motor		20HP (15kW)
油泵馬達 Hydraulic Pump Motor		2HP (1.5kW)
鋸片速度 Blade Speed		30 - 200 RPM
鋸片尺寸 Blade Size		460 mm
進刀方式 Blade Feed		伺服馬達 & 滾珠螺桿 Servo motor & Ball screw
最大送料行程 Feeding Length	單次 Single	8 - 700 mm
	多次 Multiple	700 - 7000 mm
機器與料架重量 Machine Weight With Table		4500 kg
佔地面積 WxL Floor Space (machine with table)		3120 x 7380 mm

### 規格表 SPECIFICATIONS

型號 MODEL		WS-100C
鋸切能力 Cutting Capacity	●	20 - 100 mm
	■	20x20 - 80x80 mm
鋸片馬達 Blade Motor		15HP (11.2kW)
油泵馬達 Hydraulic Pump Motor		2HP (1.5kW)
鋸片速度 Blade Speed		30 - 200 RPM
鋸片尺寸 Blade Size		360 mm
進刀方式 Blade Feed		伺服馬達 & 滾珠螺桿 Servo motor & Ball screw
最大送料行程 Feeding Length	單次 Single	8 - 600 mm
	多次 Multiple	600 - 6000 mm
機器與料架重量 Machine Weight With Table		3700 kg
佔地面積 WxL Floor Space (machine with table)		2820 x 6920 mm



### 規格表 SPECIFICATIONS

機種 MODEL		WS-75C
鋸切能力 Cutting Capacity	●	12 - 75 mm
	■	12x12 - 55x55 mm
鋸片馬達 Blade Motor		15HP (11.2kW)
油泵馬達 Hydraulic Pump Motor		2HP (1.5kW)
鋸片速度 Blade Speed		30 - 200 RPM
鋸片尺寸 Blade Size		285 mm
進刀方式 Blade Feed		伺服馬達 & 滾珠螺桿 Servo motor & Ball screw
最大送料行程 Feeding Length	單次 Single	8 - 600 mm
	多次 Multiple	600 - 6000 mm
機器與料架重量 Machine Weight With Table		3200 kg
佔地面積 WxL Floor Space (machine with table)		2620 x 6840 mm

### 規格表 SPECIFICATIONS

機種 MODEL		WS-75G
鋸切能力 Cutting Capacity	●	12 - 75 mm
	■	12x12 - 55x55 mm
鋸片馬達 Blade Motor		10HP (7.5kW)
油泵馬達 Hydraulic Pump Motor		2HP (1.5kW)
鋸片速度 Blade Speed		30 - 200 RPM
鋸片尺寸 Blade Size		285 mm
進刀方式 Blade Feed		伺服馬達 & 滾珠螺桿 Servo motor & Ball screw
最大送料行程 Feeding Length	單次 Single	8 - 600 mm
	多次 Multiple	600 - 6000 mm
機器與料架重量 Machine Weight With Table		3100 kg
佔地面積 WxL Floor Space (machine with table)		2620 x 6840 mm



### 規格表 SPECIFICATIONS

機種 MODEL		WS-100G
鋸切能力 Cutting Capacity	●	20 - 100 mm
	■	20x20 - 80x80 mm
鋸片馬達 Blade Motor		15HP (11.2kW)
油泵馬達 Hydraulic Pump Motor		2HP (1.5kW)
鋸片速度 Blade Speed		30 - 200 RPM
鋸片尺寸 Blade Size		360 mm
進刀方式 Blade Feed		伺服馬達 & 滾珠螺桿 Servo motor & Ball screw
最大送料行程 Feeding Length	單次 Single	8 - 600 mm
	多次 Multiple	600 - 6000 mm
機器與料架重量 Machine Weight With Table		3600 kg
佔地面積 WxL Floor Space (machine with table)		2820 x 6920 mm

### 1. 自動給油潤滑裝置 ( C系列：標配 / G系列：選配 )

Automatic Oiler Device ( C Type : Standard / G Type : Optional )

說明：自動給油潤滑裝置，每 160 小時自動常態性潤滑保養傳動系統。

Set the lubricant needed for automatic, punctual, and accurate injection of the transmission system per 160 hours.



### 2. 自動偵測材料外徑系統 Vise Detecting Material Size Automatically System

說明：自動偵測距切材料尺寸，防止鋸切干涉。

The automatic detection of diameter could be prevented from the interference between the vise and the material during the cutting.

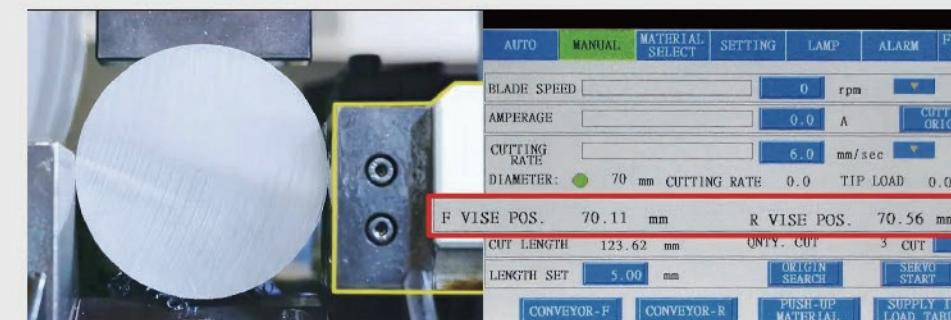

# FEEDING LOADER 自動進(儲)料架

## C - TYPE

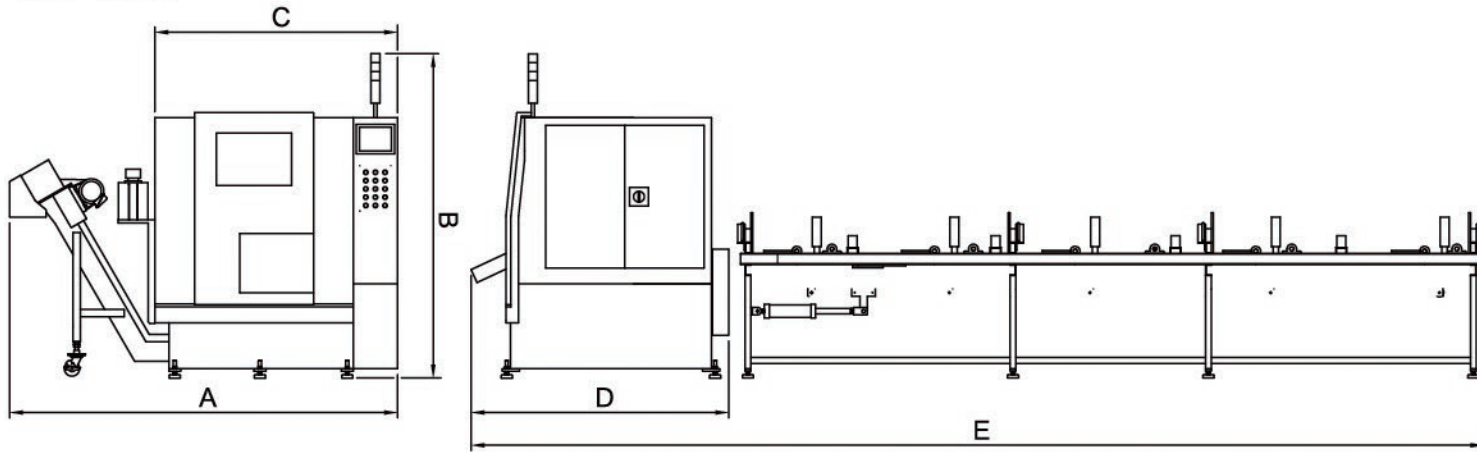

## G - TYPE

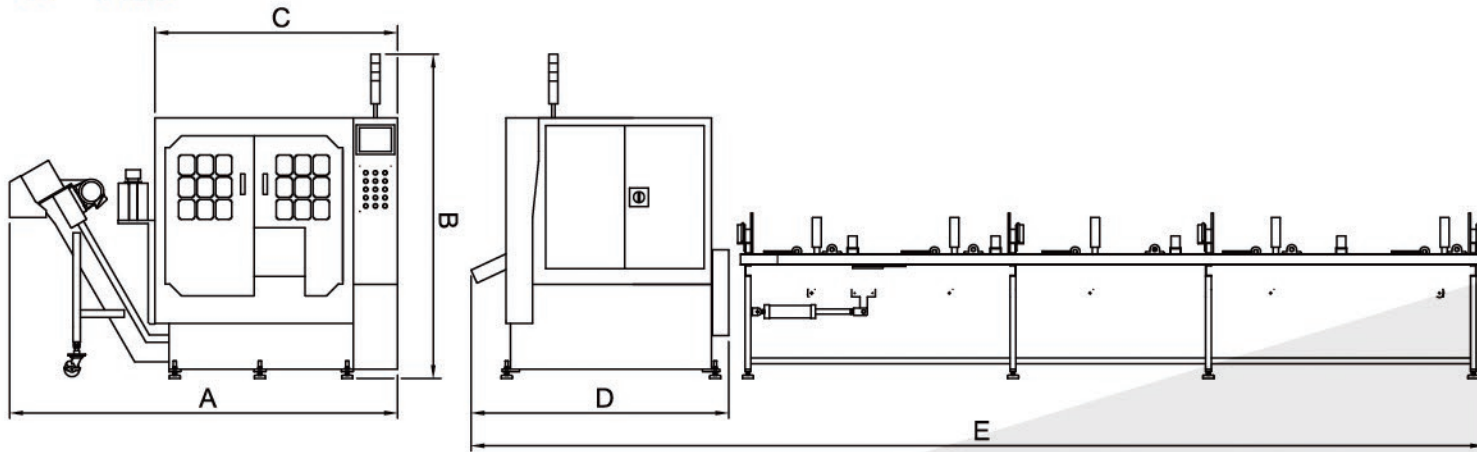

型號 MODEL	A	B	C	D	E
<b>WS-150C</b>	3,120	2,280	2,100	2,100	7,210
<b>WS-100C</b>	2,820	2,230	1,880	1,850	6,920
<b>WS-75C</b>	2,620	2,190	1,700	1,740	6,840
<b>WS-75G</b>	2,620	2,190	1,640	1,740	6,840
<b>WS-100G</b>	2,820	2,230	1,880	1,850	6,920